

2 skill level

free

Project courtesy of  
Debbie Mumm®

Crafts.  
Discover life's  
little pleasures.



tuscany table runner

**SUPPLIES & TOOLS:**

- Debbie Mumm® Tuscany Collection fabrics:
  - 1 3/4 yd Tuscany Sampler
  - 1/4 yd Olive Branch Toss
  - 1 yd Tuscany Motif Repeating Stripe
- 15"x50" batting
- Sewing machine
- Basic sewing supplies
- Iron and ironing surface

**DIRECTIONS:**

Use 1/4"-wide seam allowances throughout. Press seams in direction of arrows.

1. Cut 13 1/2"x48" Sampler fabric, centering 3 squares the length of the fabric.
2. Mark center of 13 1/2" end. Measure 3 1/2" from corner on both long sides and mark. Draw lines from each marked point to center point. Cut angle to form runner end. (FIG 1)
3. Cut four 1 1/2" strips from Olive Branch Toss. Sew 1 1/2" strip to long side of runner. Repeat for other side. Press. (FIG 2)
4. Sew 1 1/2" strip to one angled end of runner. Repeat for opposite angled end. Press and trim edges even with side and point.
5. Sew 1 1/2" strip to remaining ends of runner. Press and trim edges. (FIG 3)
6. Place runner top right sides together with backing and layer on batting. Cut backing and batting to size and shape of runner. Sew around all edges leaving 5" opening for turning.
7. Clip corners, turn, and press.
8. Sew opening closed and quilt.

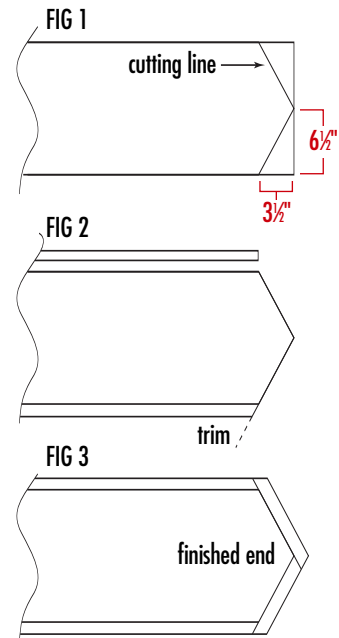

just ask, Jo-Ann how to

more projects, tips & techniques at Joann.com®

Skill Level 2: Some sewing experience needed

Approximate Crafting Time: 2 hours

Please read and follow all manufacturers' instructions for all tools and materials used. Provide adult supervision if children participate in this project. ©2009 Jo-Ann Stores, Inc. All rights reserved.

**JOANN**  
fabric and craft stores®  
P150-310