

splurge patchwork yoga mat & tote free

skill level 3



more projects, tips & techniques at Joann.com®

Craft with Jo-Ann

YOGA MAT

SUPPLIES & TOOLS:

- Splurge fabrics for the Stonehill Collection by Donna Wilder
 - 1½ yd. coral/peach floral
 - 2 yds. coral geometric circle
 - ¼ yd. each of white on peach floral, paisley, green circle, and floral on light green
 - ¾ yd. white on green floral for binding
- Twin size low loft polyester or polyester blend quilt batting
- ¾ yd. 18" wide non-slip fabric with plastic dots
- Basic sewing supplies
- Sewing machine
- Iron & pressing surface

DIRECTIONS:

1. Follow steps 2 through 7 for cutting fabric for the Yoga Mat.
2. From coral/peach floral, cut a 60½" x 13" center rectangle centering the flowers on the piece. Cut a 24" x 20¼" piece for the back.
3. Cut one 3" wide crosswise strip from each of green circles and white on green floral. Cut two 3" wide crosswise strips from each of white on peach floral, paisley and floral on light green.
4. From coral geometric circles, cut two side borders 65½" x 3 ¼" and two top and bottom borders 24½" x 3¼". Cut two back pieces 24" x 20¼".
5. From white on green floral, cut five crosswise binding strips 1¾" wide. Trim the ends diagonally.
6. Cut two 25" x 74" rectangles from quilt batting.
7. From non-slip fabric with plastic dots, cut two 24½" x 3½" strips and two 24½" x 4" strips.
8. Follow steps 9 through 23 for construction of the Yoga Mat. Stitch all seams right sides together using ¼" seam allowance unless otherwise indicated.
9. Arrange the fabric strips in the following order: paisley, peach, light green floral, white on green floral, paisley, peach, light green floral, green geometric circles. Stitch the strips together in pairs.

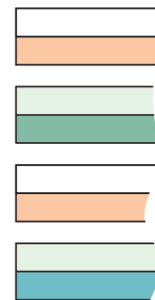

9

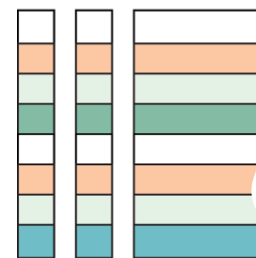

10

10. Stitch the pairs together to make one piece. Measure and cut the joined strips into eight 3" wide patchwork strips.
11. Stitch three patchwork strips together to make each side border. Stitch the side borders to the sides of the center rectangle. Remove one square from the two remaining patchwork strips. Stitch to the top and bottom of the center

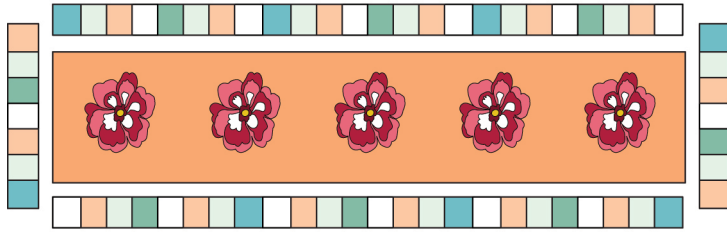

rectangle and patchwork squares.

12. Stitch the side borders to the sides of the patchwork strips. Stitch the top and bottom to the top and bottom edges.
13. Stitch the 3 1/2" wide non-slip strips to the ends of the coral/peach floral back. Stitch the 4" wide non-slip strips to one end of the coral geometric circle backs. Stitch the opposite fabric edges to edges of the center back to complete the back.
14. Draw lines on the fabric sections of the back evenly spaced slightly less than 4" apart parallel to edges of the non-

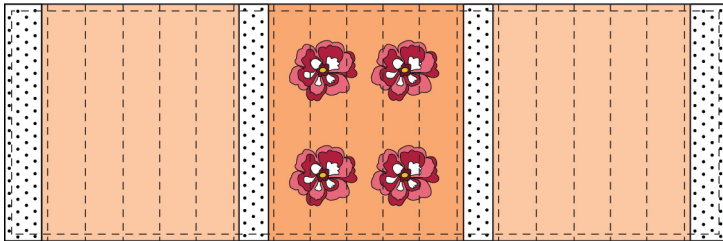

slip strips.

15. Center the top of the mat on one the quilt batting pieces. Center the bottom of the mat on the other one. Pin and baste the layers together.
16. On the top, using matching thread, quilt around the flower motifs on the center. Quilt along some of the pink swirls between the flowers. Quilt one quarter inch from the seams between the patchwork squares. Quilt 1/4" from the seams of the outer border.
17. On the bottom, quilt along the drawn lines and along the seam lines of the non-slip strips.
18. With the fabric sides facing out, pin then baste the top and the bottom together along the outer edges and along the outer seamline of the center. Quilt "in the ditch" along the outer seamline of the center through all the layers.

19. Press under 1/2" on one end and the long edges of the ties and fold it in half. Stitch the edges together.

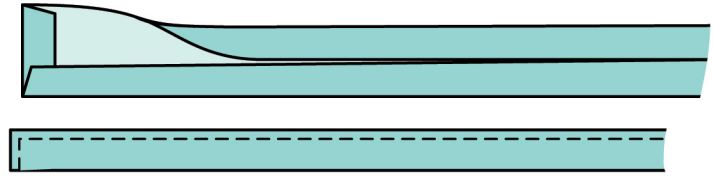

20. Baste the unfinished ends to the center of back of the mat.

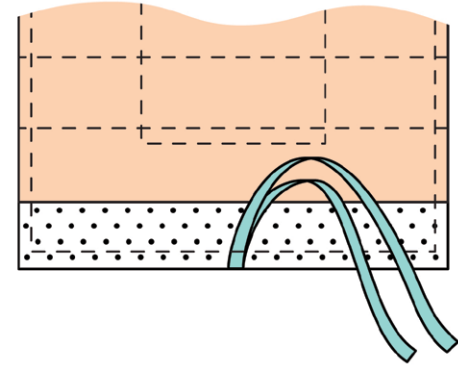

21. Pin the binding around the edges of the top of the mat mitering the binding at the corners. Stitch 3/8" from the edges. Join the ends neatly.
22. Fold the binding to the wrong side turning under the edge along the seamline and again mitering the corners. Slip stitch the edges in place.

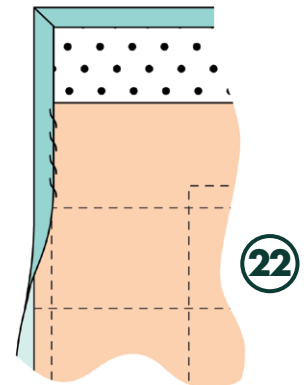
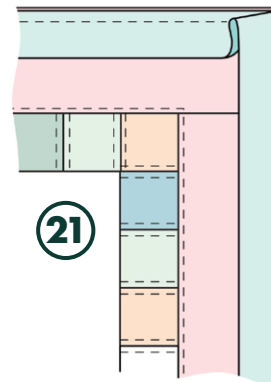

YOGA TOTE

SUPPLIES & TOOLS:

- Splurge fabrics for the Stonehill Collection by Donna Wilder
 - 3/4 yd. large coral/peach floral
 - 3/4 yd. coral geometric circle
 - 1/8 yd. each white on peach floral, white on green floral, paisley, green circle, and floral on light green
- NOTE: If you are making the mat you do not need to purchase an additional amount of these fabrics.
- 1 yd. canvas for lining
- 1/4 Peltex interfacing
- 3/4 yd. narrow cotton cording
- Two 1 1/2" standard slides
- 7" zipper to match large floral fabric
- Sewing Machine
- Iron and pressing surface
- Basic sewing supplies
- Needles and pins
- Rotary cutter, ruler and cutting mat - optional

DIRECTIONS:

1. Follow the directions in steps 2 through 8 for cutting fabric for the Yoga Tote.
2. From coral/peach floral, cut one upper tote 23"x17 1/4", one 8"x8" lower pocket and one 8"x1 3/4" upper pocket. Cut a 24"x1 1/2" bias strip for cording.
3. From coral geometric circles, cut one lower tote 23"x9 3/4", one upper strap 40 1/2"x4" and one lower strap 9"x4". Cut two bottom circles 8" in diameter.
4. From white on green floral cut one draw string 34"x2" and one pocket binding 30"x1 1/2".
5. From canvas, cut one bag lining 27 1/2"x23", one strap 1 1/2"x40 1/2", one strap 9"x1 1/2", and lining for the pocket pieces 8"x7 1/2" and 8"x1 1/4".
6. From Peltex, cut one 7" diameter circle.
7. Cut one 2 1/2"x2 1/2" squares from paisley, green circles, white on green floral, white on peach floral and light green print. Then cut a total of four more squares from these fabrics. Omit this step if you have made the Yoga Mat and have some strip piecing left over.
8. If you wish to make the Yoga Tote from one fabric. Cut one piece 28 3/4"x23". Cut pocket binding 38" long.
9. Follow the directions in steps 10 through 29 for construction of the Yoga Tote. Stitch all seams right sides together using 1/2" seam allowance unless otherwise indicated.

10. Pin the canvas pocket lining pieces on the wrong side of the fabric pocket pieces matching the top edges on the upper pocket and the bottom edges on the lower pocket. Baste along the edges that are matching. Press the remaining edges of the fabric to the wrong side over the edges of the canvas.
11. Pin the finished edges of the pocket pieces to the edges of the zipper. Stitch along the edges of the fabric.
12. Pin the binding around the side and bottom edges of the canvas side of the pocket mitering the binding at the corners and stitch 3/8" from the edges. (If you are making the bag from one fabric only, bind the top edge of the pocket as well joining the edges of the binding neatly.)
13. Fold the binding to the right side turning under the edge along the seamline and again mitering the corners and stitch it in place.
14. Pin the pocket to the center of the top edge of the lower tote piece. (If you are using only one fabric, center the pocket on the tote about 1 1/2" from the lower edge.) Stitch the edges to the tote along the outer edge of the binding.

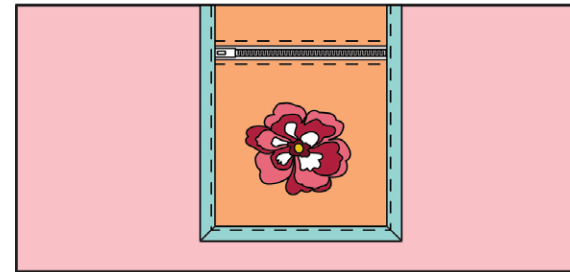

15. Stitch the squares together to make a patchwork strip.
16. Center the patchwork strip along the top edge of the lower tote. Stitch the seam using a 1/4" seam allowance. Trim the patchwork strip even with the side edges of the tote. Stitch the upper tote to the remaining edge of the patchwork strip using a 1/4" seam allowance.

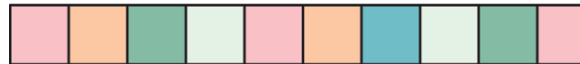

10

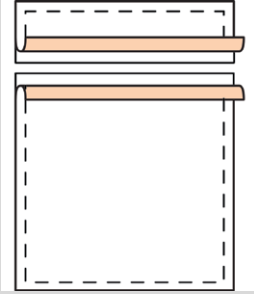

11

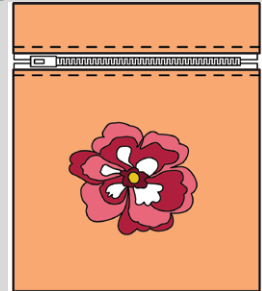

12

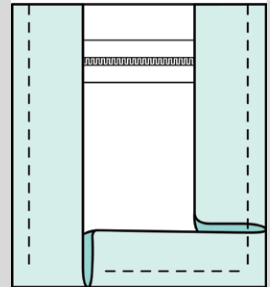

13

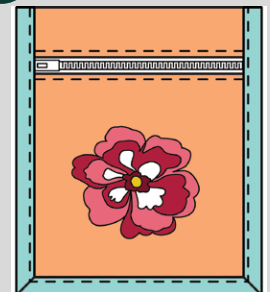

17. Right side up, pin the tote to the canvas lining matching the side and lower edges. Baste $\frac{3}{8}$ " from the side and lower edge. Baste along the top edge of the canvas.
18. Quilt $\frac{1}{4}$ " from the seams of the upper and lower tote sections. Quilt along the side edges of each patchwork square.
19. Mark the center of the top edge of the tote. Make two $\frac{1}{2}$ " long buttonholes $\frac{1}{2}$ " from the center line beginning $\frac{1}{8}$ " from the top edge.
20. Stitch the side edges of the tote together to make a cylinder. Zigzag finish the seam allowance.
21. Press under $\frac{1}{2}$ " then $\frac{3}{4}$ " along the top edge to make the casing. Stitch along the bottom edge of the casing.
22. Baste the canvas to $\frac{1}{2}$ of the strap pieces with the edge of the canvas even with the lengthwise center of the straps. Press under $\frac{1}{2}$ " seam allowance on the lengthwise edges of the straps. Fold the straps in half and top stitch along the edges of the strap.

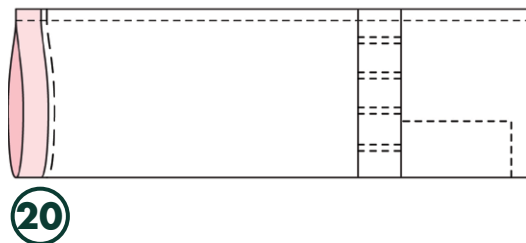

20

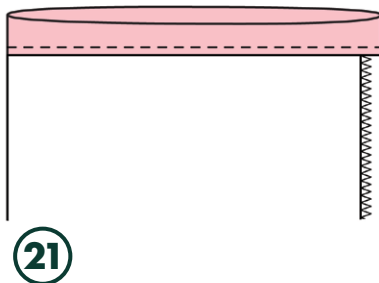
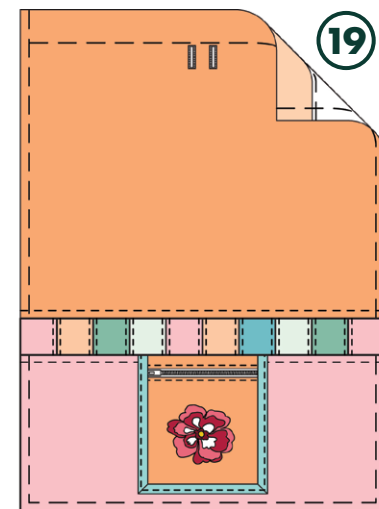

21

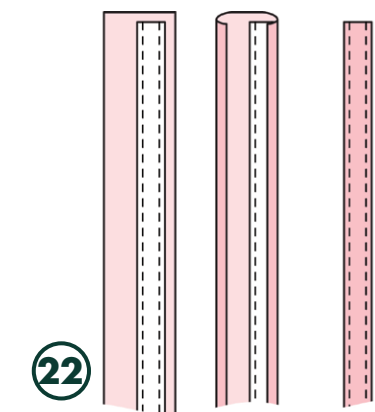

22

23. Pin the lower strap to the bottom edge of the tote cylinder centered over the seam. Stitch it in place along the bottom. Slip one of the slides over the top end of the strap. Fold the strap about $2\frac{1}{2}$ " from the top end and pin this point to the tote. Stitch along the side edges of the lower strap and across the strap to hold the strap securely to the tote.

24. Insert one end of the upper strap over the center of the second slide and fold the strap about $2\frac{1}{2}$ " from the end. Turn under the seam allowance on the end and stitch it top the strap.

25. Slide the remaining end of the strap through the first slide at the top of the lower strap and then through the second slide. Turn under $\frac{1}{2}$ " on the top end of the strap and pin the upper $2\frac{1}{2}$ " to the tote centered over the seam just below the casing. Stitch the strap to the tote.

26. Place one fabric bottom circle wrong side up. Center the Peltex circle on top. Then place the remaining fabric circle right side up matching the edges. Baste the fabric layers together along the seam line using a zipper foot.

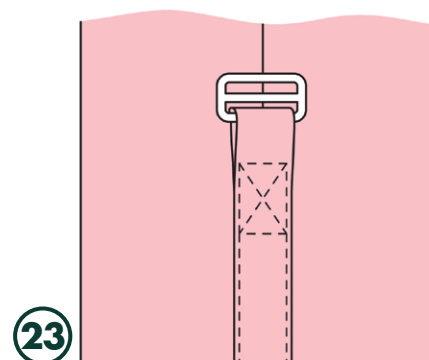

23

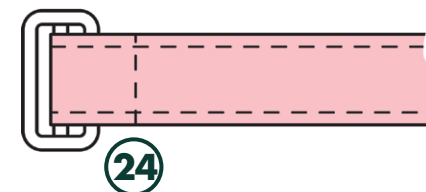

24

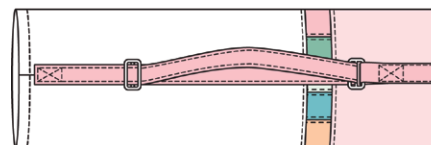

25

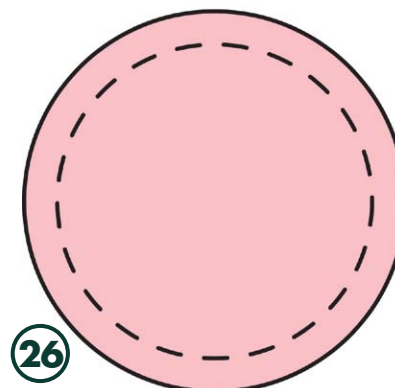

26

27. Fold the bias strip in half lengthwise inserting the cotton cording along the fold. Baste along the edge of the cording using a zipper foot. Baste the cording around the bottom circle matching the seamlines. Finish the ends neatly.

28. Clip the bottom edge of the tote at $\frac{3}{4}$ " intervals. Pin the tote to the edges of the circle with the cording sandwiched between the pieces. Stitch along the seam line. Zigzag finish the edges. Turn the tote right side out.

29. Press under $\frac{1}{2}$ " on all edges of the drawstring and fold it in half. Stitch the edges together. Insert the drawstring in the casing using a large safety pin.

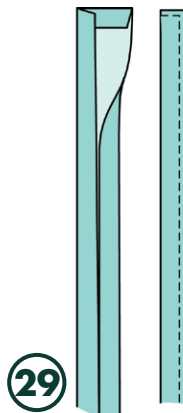
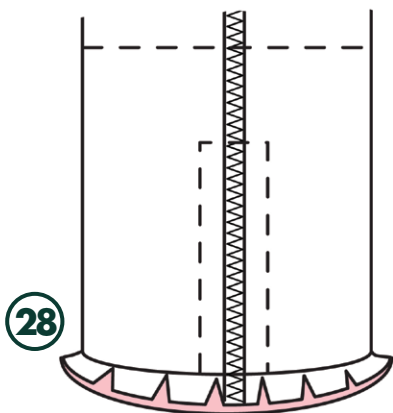
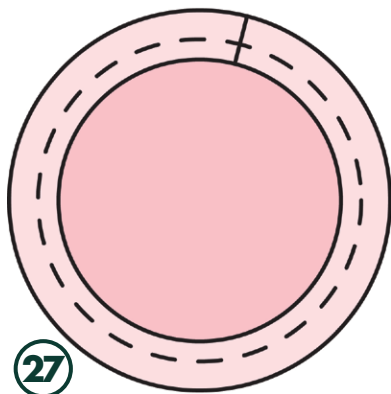

Created by Splurge Fabrics

Skill Level 3: Experience necessary

Please read and follow all manufacturers' instructions for all tools and materials used.
Provide adult supervision if children participate in this project.
©2012 Jo-Ann Stores, Inc.

JO-ANN
fabric and craft stores®